



GEODE-OSB

Rugged AGX Orin Computer System

User Manual

Revision A3

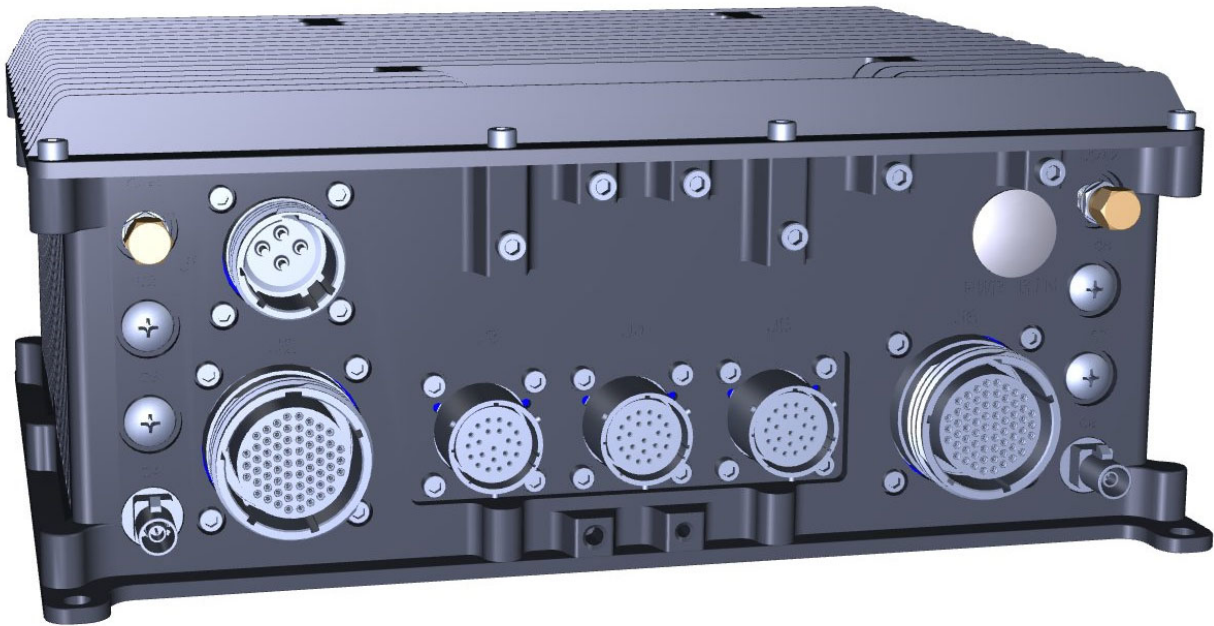

Revision	Date	Comments
0.1	06/25/2024	Initial Version
0.2	08/21/2024	Version with connector pinout table updates
A3	11/30/2024	Formatting cleanup

**FOR TECHNICAL SUPPORT
PLEASE CONTACT:**

support@diamondsystems.com

© Copyright 2024
Diamond Systems Corporation
158 Commercial Street
Sunnyvale, CA 94086 USA
Tel 1-650-810-2500
www.diamondsystems.com

TABLE OF CONTENTS

1. IMPORTANT SAFE HANDLING INFORMATION	3
2. DESCRIPTION	4
2.1 SYSTEM FEATURES	4
2.2 EXTERNAL CONNECTOR AND FEATURES	4
2.3 INTERNAL CONNECTOR DETAILS.....	5
2.4 OPERATING SYSTEM SUPPORT.....	5
2.5 MECHANICAL, ELECTRICAL, ENVIRONMENTAL.....	5
2.6 AGX ORIN MODULES OVERVIEW	6
3. KEY SUBSYSTEMS	7
3.1 NVIDIA GPU MODULE	7
3.2 POWER SUPPLY SPECIFICATIONS	7
3.3 POWER SWITCH	8
3.4 BACKUP BATTERY	8
3.5 ETHERNET PORTS	8
3.6 DISPLAY	8
3.7 GMSL CAMERA INTERFACE.....	8
3.8 AUDIO INTERFACE.....	8
3.9 SERIAL PORTS.....	8
3.10 PCIe MINICARD SOCKET.....	9
3.11 USB	9
3.12 PCIe M.2 M-KEY SOCKET	9
3.13 M.2 E-KEY SOCKET	9
3.14 DIGITAL I/O.....	9
3.15 CAN.....	9
3.16 UTILITY	9
3.17 EXPANSION IO.....	9
4. KEY INTERFACES	10
5. SYSTEM ARCHITECTURE	11
6. INTERNAL FEATURES	12
7. MECHANICAL DRAWINGS	13
8.1 J1 - POWER INPUT.....	15
8.2 J2 – MULTI-I/O CONNECTOR.....	16
8.3 J3 – 10Gb ETHERNET	19
8.4 J4 – HDMI	21
8.5 J5 – USB3.2	23
9. JUMPER CONFIGURATION	25
9.1 JUMPER BLOCKS.....	25
9.2 SERIAL PORT TERMINATION (JP1).....	25
9.3 DIO JUMPER SELECTION (JP2).....	26
9.4 CONFIGURATION JUMPER SELECTION (JP3)	26

1. IMPORTANT SAFE HANDLING INFORMATION

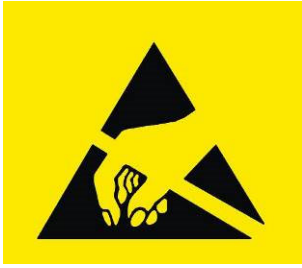

WARNING!

ESD-Sensitive Electronic Equipment

Observe ESD-safe handling procedures when working with this product.

Always use this product in a properly grounded work area and wear appropriate ESD-preventive clothing and/or accessories.

Always store this product in ESD-protective packaging when not in use.

Safe Handling Precautions

The product contains high density connectors with many connections to sensitive electronic components. This creates many opportunities for accidental damage during handling, installation and connection to other equipment. The list here describes common causes of failure found on boards and systems returned to Diamond Systems for repair. This information is provided as a source of advice to help you prevent damaging your Diamond (or any vendor's) boards.

ESD damage – This type of damage is usually almost impossible to detect, because there is no visual sign of failure or damage. The symptom is that the board eventually simply stops working, because some component becomes defective. Usually the failure can be identified and the chip can be replaced. To prevent ESD damage, always follow proper ESD-prevention practices when handling computer boards.

Power supply wired backwards – Our power supplies and boards are not designed to withstand a reverse power supply connection. This will destroy each IC that is connected to the power supply (i.e. almost all ICs). In this case the board will most likely will be unrepairable and must be replaced. A chip destroyed by reverse power or by excessive power will often have a visible hole on the top or show some deformation on the top surface due to vaporization inside the package. **Check twice before applying power!**

2. DESCRIPTION

Geode Osbourne is a Jetson AGX Orin module-based rugged computer system from Diamond Systems with rich graphics and camera inputs capability. This Geode system converts Jetson module into a complete rugged system by providing standard D38999 Series III connectors and MIL Grade High Speed Rugged Circular connector for all the major features of the module, power supply and additional I/O capabilities.

Geode System is the latest product from Diamond Systems to integrate the newly released Standalone NVIDIA AGX Orin System on Modules (SoM).

2.1 System features

SI No	Component	Feature	Qty
1	Power	7 to 20V DC wide supply or 9 to 36V DC supply(With Power Filter Board)	1
2	CPU	NVIDIA AGX Orin Module - 12-core Arm Cortex-A78AE v8.2 64-bit CPU 3MB L2 + 6MB L3	1
3	HDMI	D38999	1
4	Ethernet	1x 1Gbps, 1x10Gbps	2
5	USB	USB2.0 & USB3.0	2x USB2.0, 2x USB3.0
6	Digital I/O	Extended I/O capability	8
7	Serial Port	RS232/RS422/RS485	2xRS232/RS422/RS485 2xRS232
8	CAN	Version 2.0A, Version 2.0B	2 Ports
9	Utility	I2C, SPI & Power Signals	1

2.2 External Connector and Features

Feature	Description	Connector Type
Power	+7V to +20V DC / +9V to +36V input supply with MIL-STD-461 filtering	D38999/20WC4PN
USB	2x USB 3.2 from the Orin module	SJT00RT12-35S014
	2x USB2.0 from the Orin module	D38999/20WF35SN
Ethernet	Gigabit Port - 10/100/1000Mbps from Orin module	D38999/20JD35SN
	10G Port – 10Gbps from Osbourne Carrier Board	SJT00RT12-35DS014
Display	1x HDMI 2.0a/b directly from the Orin module	SJT00RT12-35S014
Camera	Up to 8 GMSL Camera support	FAKRA Connector
DIO	8 Digital IO via I2C to GPIO	D38999/20WF35SN

CAN	2x CAN with Non isolated transceivers	D38999/20WF35SN
Audio	Via ALC5640 CODEC	D38999/20WF35SN
Utility	PWR_BTN, RESET, FORCE RECOVERY, I2C(3.3V)	D38999/20WF35SN
Antenna	Support for two SMA connectors on the enclosure	SMA connector on enclosure
Expansion IO	Three qty of 2x10 pin expansion I/O support	D38999/20WF35SN
Serial Ports	2 x ports Software configurable RS-232/422/485 through SP336 transceivers with bypass option to access TTL signals	D38999/20WF35SN
	2x ports fixed RS-232 through SP3243 transceivers with bypass option to access TTL signals	D38999/20WF35SN

2.3 Internal Connector Details

Feature	Description	Connector Type
RTC	3V power input for RTC functionality	BC2032-E2
Mass Storage	2x mPCIe socket	1759547-1 on Carrier board
	1 M.2 M Key (2280 or 2242) (NVMe) expansion slots (4 lane PCIe Gen 3)	10128798-005RLF on Carrier board
	1 M.2 E key 2230	2199230-4 on Carrier board

Note: Refer to Osbourne Carrier Board user manual for more information on the carrier board features.

2.4 Operating System Support

Linux Kernel version 4.4.38; Ubuntu 20.04

2.5 Mechanical, Electrical, Environmental

Form factor	9.5"x8.5"x3.85"
Cooling	Conduction Cooling
Power input	+7V to +20V DC / 9 to +36V DSC with Filter Circuit
Operating Temp	-40°C to +80°C
Weight	Base model: 5.5 lb / 2.5Kg

2.6 AGX Orin Modules Overview

Measuring 100mm x 87mm module, Bring your next-gen products to life with the world's most powerful AI computer for energy-efficient autonomous machines. Up to 8X the performance of the last generation, 275 TOPS for multiple concurrent AI inference pipelines, and high-speed interface support for multiple sensors make this the ideal solution for applications from manufacturing and logistics to retail and healthcare.

AGX Orin Series Feature Description

Feature	Description	
	AGX Orin 32GB	AGX Orin 64GB
GPU	1792-core NVIDIA Ampere architecture GPU with 56 Tensor Cores	2048-core NVIDIA Ampere architecture GPU with 64 Tensor Cores
AI Performance	200 TOPS	275 TOPS
GPU Max Frequency	939 MHz	1.3 GHz
CPU	8-core Arm® Cortex®-A78AE v8.2 64-bit CPU 2MB L2 + 4MB L3	12-core Arm® Cortex®-A78AE v8.2 64-bit CPU 3MB L2 + 6MB L3
CPU Max Frequency	2.2 GHz	2.2 GHz
Memory	32GB 256-bit LPDDR5 204.8GB/s	64GB 256-bit LPDDR5 204.8GB/s
Video Encode	1x 4K60 (H.265) 3x 4K30 (H.265) 6x 1080p60 (H.265) 12x 1080p30 (H.265)	2x 4K60 (H.265) 4x 4K30 (H.265) 8x 1080p60 (H.265) 16x 1080p30 (H.265)
Video Decode	1x 8K30 (H.265) 2x 4K60 (H.265) 4x 4K30 (H.265) 9x 1080p60 (H.265) 18x 1080p30 (H.265)	1x 8K30 (H.265) 3x 4K60 (H.265) 7x 4K30 (H.265) 11x 1080p60 (H.265) 22x 1080p30 (H.265)
Power	15W - 40W	15W - 60W
Networking	1x GbE 1x 10GbE	
Storage	64GB eMMC 5.1	
DL Accelerator	2x NVDLA v2	
DLA Max Frequency	1.4 GHz	
Vision Accelerator	1x PVA v2	
Camera	Up to 6 cameras (16 via virtual channels*) 16 lanes MIPI CSI-2 D-PHY 2.1 (up to 40Gbps) C-PHY 2.0 (up to 164Gbps)	
USB	3x USB 3.2 Gen2 (10 Gbps) 4x USB 2.0	
Display	1x 8K60 multi-mode DP 1.4a (+MST)/eDP 1.4a/HDMI 2.1	
Other I/O	4x UART, 3x SPI, 4x I2S, 8x I2C, 2x CAN, PWM, DMIC & DSPK, GPIOs	
PCIe	Up to 2 x8 + 1 x4 + 2 x1 (PCIe Gen4, Root Port, & Endpoint)	
Mechanical	100mm x 87mm 699-pin Molex Mirror Mezz Connector Integrated Thermal Transfer Plate	

3. KEY SUBSYSTEMS

3.1 NVIDIA GPU Module

The Geode Osbourne supports Jetson™ AGX Orin Series modules.

Jetson AGX Orin module features up to 275 TOPS and 8X the performance of the last generation for multiple concurrent AI inference pipelines, plus high-speed interface support for multiple sensors, Jetson Orin modules provide the ideal solution for a new age of Robotics and AI at the edge applications.

The following modules from NVIDIA are supported in Geode Osbourne:

- AGX Orin 32GB
- AGX Orin 64GB
- AGX Orin 64GB Industrial

3.2 Power Supply Specifications

Geode Osbourne supports two powering options as shown in the illustration below:

1. Integrated MIL-STD-461 power filter circuit on Rugged Panel I/O board
2. JMM-7515-IF external power supply with MIL-STD-461/704/1275 compliance, input-to-output isolation, and 80W max output power; this power supply will generate 15VDC output to power the Osbourne and other electronics inside the enclosure.

Without the JMM-7515 power supply, the Geode Osbourne can be powered from a wide input voltage range of +7V to +20V. With the JMM-7515 installed, Geode Osbourne can be powered from +9V to +36V.

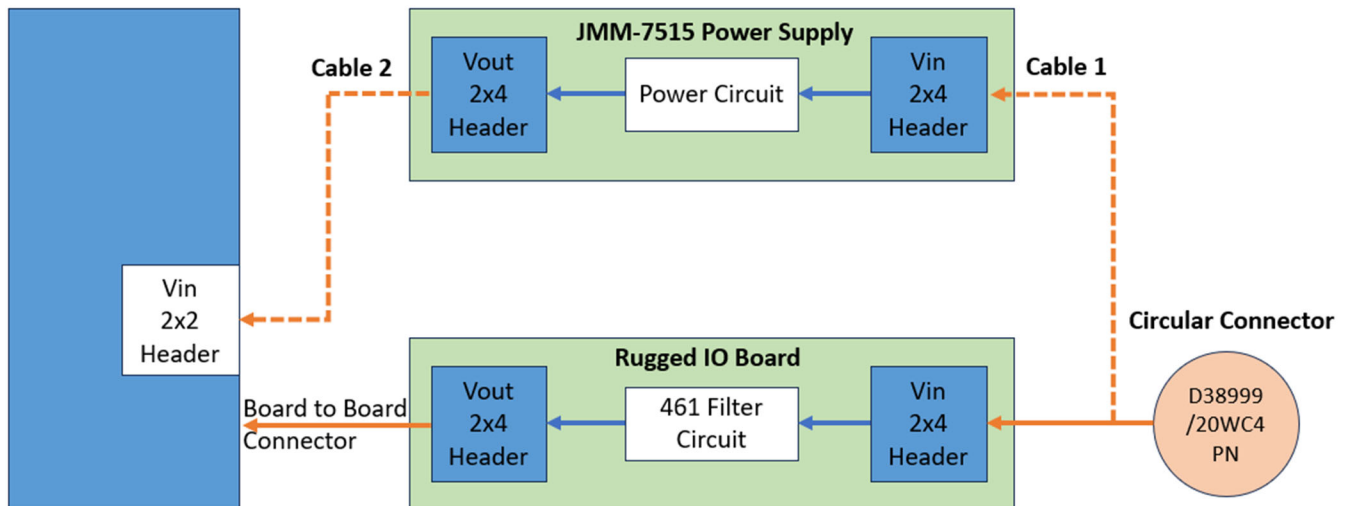

3.3 Power Switch

Geode Osbourne system provides a push button power switch on the front panel. The operation of the power switch is as follows.

Short press (debounce time is > 20ms) will power on the system. Once the system is powered, a long press of more than 10 seconds duration will force shutdown the system. Short press when the system is powered on will prompt the shutdown/restart menu. Then the user can opt for the appropriate action.

3.4 Backup Battery

A 2032 coin horizontal battery holder is provided on rugged IO board. The Geode Osbourne can boot and function normally without a backup battery as well. RTC of Orin module backup voltage of 3V with 1.8V to 3.46V max is required.

3.5 Ethernet Ports

Geode-OSB offers two Ethernet ports:

- 10G Ethernet port derived using MGBE interface from Orin module using 10G ethernet PHY.
- The 10/100/1000 Ethernet port uses RGMII interface from Orin module through a 1G PHY.

Both ethernet interfaces are available on the MIL grade circular connectors. 10G interface is available on J3 and GBE si available on J2 on the front panel. Both ports utilize 4 copper twisted pair connections.

3.6 Display

The board offers one HDMI video output option. The HDMI port is directly from the Module and made available on the rugged I/O connector J4. All the common choke and ESD protection circuitry are provided on the baseboard. I2C level shifting, and load switch need to be on the IO board.

3.7 GMSL Camera Interface

Geode Osbourne supports up to 8 GMSL cameras on the front panel through rugged, sealed FAKRA connectors. The GMSL interfaces are brought out through the optional Diamond systems GMSL adapter board. AMC to FAKRA cable assemblies are used to bring the camera connections to the 8 multi-purpose cutouts on the front panel of the enclosure. The number of camera ports available is reduced by the number of antennas in use, since the two features share the same front panel cutouts.

3.8 Audio Interface

Geode-OSB provides audio support from a ALC5640 audio chip. Audio I/O signals include stereo line out and mono/stereo mic in. The audio signals are made available on the rugged circular connector J2.

3.9 Serial Ports

Geode-OSB supports up to 4 serial ports. Two ports feature RS-232/422/485 capability and are derived using a single SP336 transceiver. As a result both ports are configured for the same protocol. The protocol is selected via GPIO pins from the Orin module. A jumper option is provided on the Osbourne carrier board to select termination (120 Ohm) if desired.

Another two fixed RS-232 protocol ports are derived using a MAX3243EIPW transceiver. These serial ports can be configured to bypass the serial transceiver to provide 3.3V logic level signaling.

3.10 PCIe Minicard Socket

Geode-OSB supports one full-size minicard using socket 1 (J12) that supports both PCIe x1 and USB 2.0 connectivity to the Orin module. A second socket J13 is provided on the board but requires a custom configuration of the OS to change the operating mode of the Orin module.

The carrier board is preconfigured with 2 M2 threaded spacers for installing a full-size minicard. An M2 threaded hole is installed on the opposite side of the carrier board for mounting a standoff to install a half-size minicard if desired.

3.11 USB

Geode-OSB supports 2x USB2.0 ports routed to rugged I/O connector J2. Two USB3.2 ports with USB 2.0 fallback are also routed to the rugged USB connector J5.

3.12 PCIe M.2 M-Key Socket

Geode-OSB offers an M.2 PCIe based SSD module socket. x4 PCIe lanes from the AGX Orin module is routed to the M.2 M-Key 2280/2242 socket. An M3 threaded standoff is installed on the socket side of the Osbourne carrier board to mount the default 2280 size module. A second M3 threaded standoff is provided on the opposite of the carrier board to enable installation of mounting hardware for a 2242 size module if desired.

3.13 M.2 E-Key Socket

An M.2 2230 E-key socket is provided on the carrier board. The socket supports a PCIe x1 interface. Antennas for the installed module utilize the multi-purpose cutouts on the left and right sides of the enclosure. These cutouts support SMA style connectors.

3.14 Digital I/O

Geode-OSB provides 8x digital I/O's, which are individually configurable as an output or input. Digital I/Os are realized using an I2C GPIO expander. The expander device is accessible on the I2C address 0x22. The I/Os are routed to the rugged I/O connector J2. On board ESD protection is provided.

Provision is to select the DIO Voltage level of 3.3/5V and configure Pull up and pull down through the Jumper JP2 is provided. Refer Jumper section for more details.

3.15 CAN

Geode-OSB provides two CAN interface from the AGX Orin module to the Rugged I/O connector J2. MCP2551T-I/SN CAN transceiver is used with baud rates support from 60 kbaud up to 1 Mbaud.

3.16 Utility

Power button, Force recovery, Reset and I2C signals are also made available on the circular connector J2.

3.17 Expansion IO

Geode-OSB also provides another rugged circular connector J6 on the enclosure. This can be used for IO expansion using an installed minicard or other electronics.

4. KEY INTERFACES

The interfaces on Geode Osbourne are derived from the different subsystems. A summary of the interfaces provided on the system with its provider are tabulated below:

SI No	Interface	Subsystem
1	HDMI	AGX Orin
2	2G Ethernet	AGX Orin
3	10G Ethernet	Derived from 10G CTRLR+PHY AQR113-B0-I
4	2xUSB3.2	AGX Orin
5	2xUSB2.0	AGX Orin
6	8xDIO + 2xGND	Derived from IO Expander PCA9535AHF
7	2xRS-232/RS422/RS485	Derived from SP336
8	2xRS-232 TX/RX/GND	Derived from SP336
9	2xCAN/GND	From AGX Orin through MCP2551T Txvr
10	AUDIO OUT L/R, MIC IN, AUDIO_GND	From ALC5640 Audio CODEC
11	1x I2C	AGX Orin
Power		
10	Power	Through external power filter (JMM-7515) or through onboard power filter on rugged IO board

5. SYSTEM ARCHITECTURE

Figure 1 provides an overview of the block diagram of the Geode-OSB rugged system.

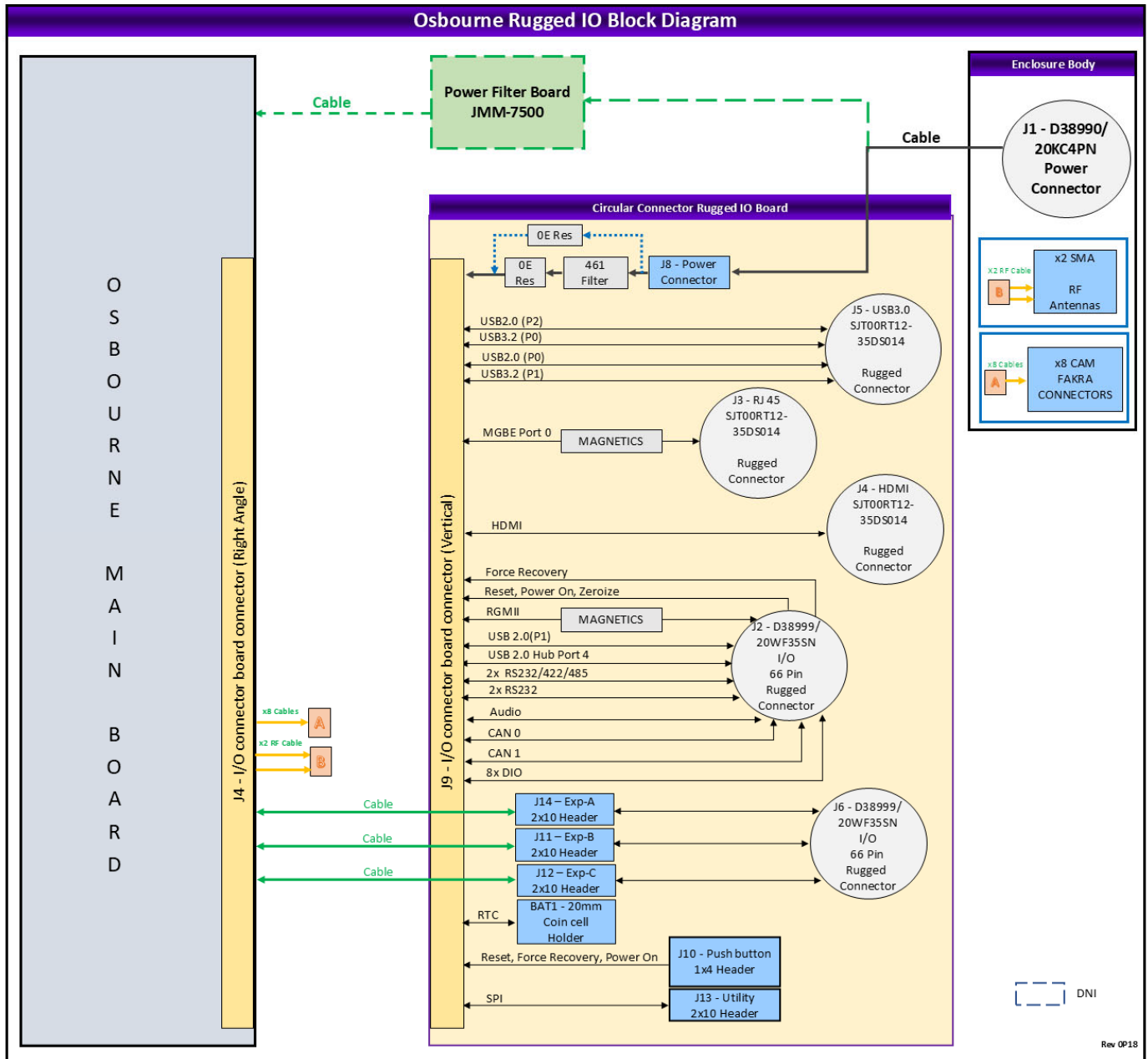
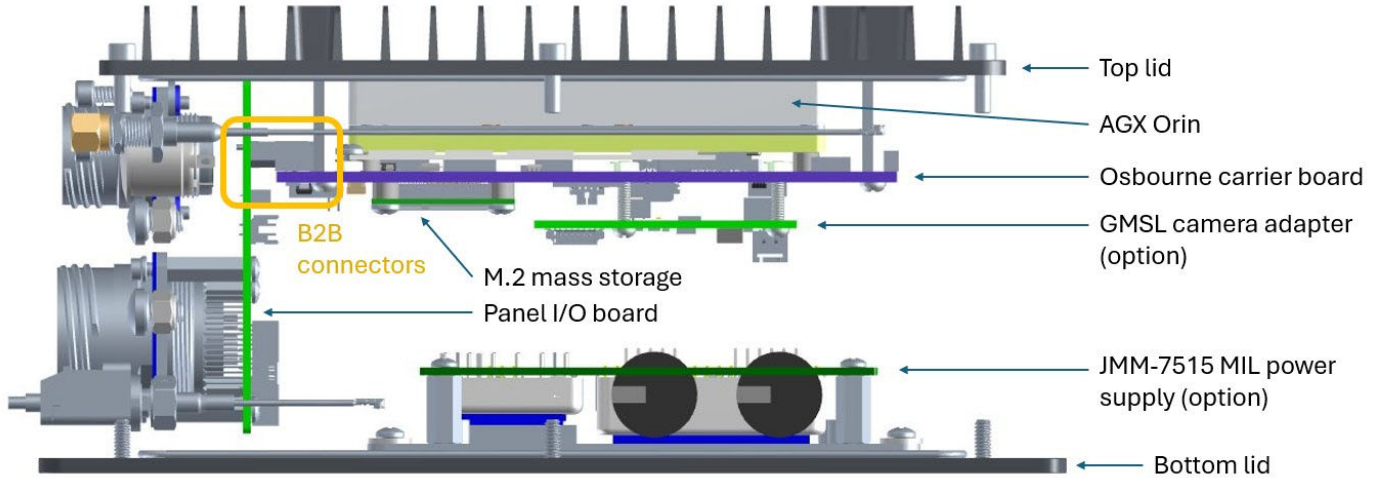

Figure 1: System Architecture of Geode-OSB

6. INTERNAL FEATURES

The below illustration shows the internal construction of Geode-OSB. Note the AGX Orin carrier board is directly coupled via board-to-board “B2B” connectors to the “panel I/O” board with its PCB-mounted I/O connectors. This construction technique eliminates most internal cables and reduces the overall size of the system, while increasing ruggedness.



7. MECHANICAL DRAWINGS

The form factor of the system is 241mm W x 215mm D x 98mm H / 9.5" x 8.5" x 3.85".

All dimensions in the below drawings are in mm.

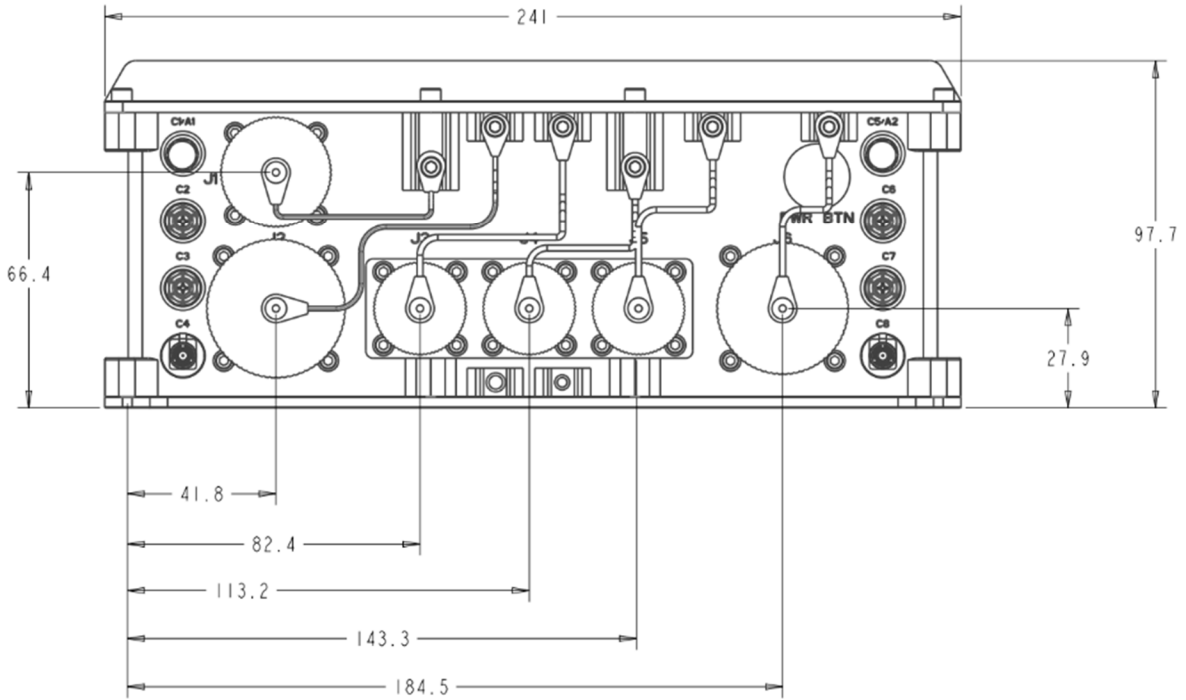

Figure 2: Mechanical outline, front view

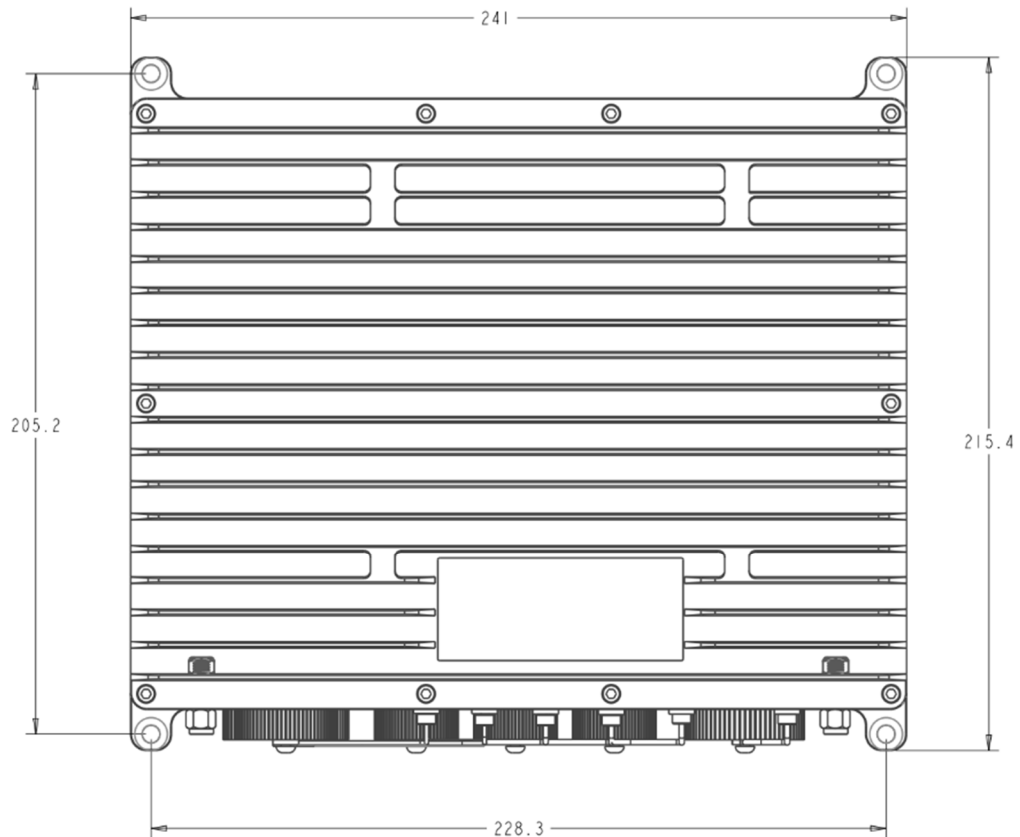
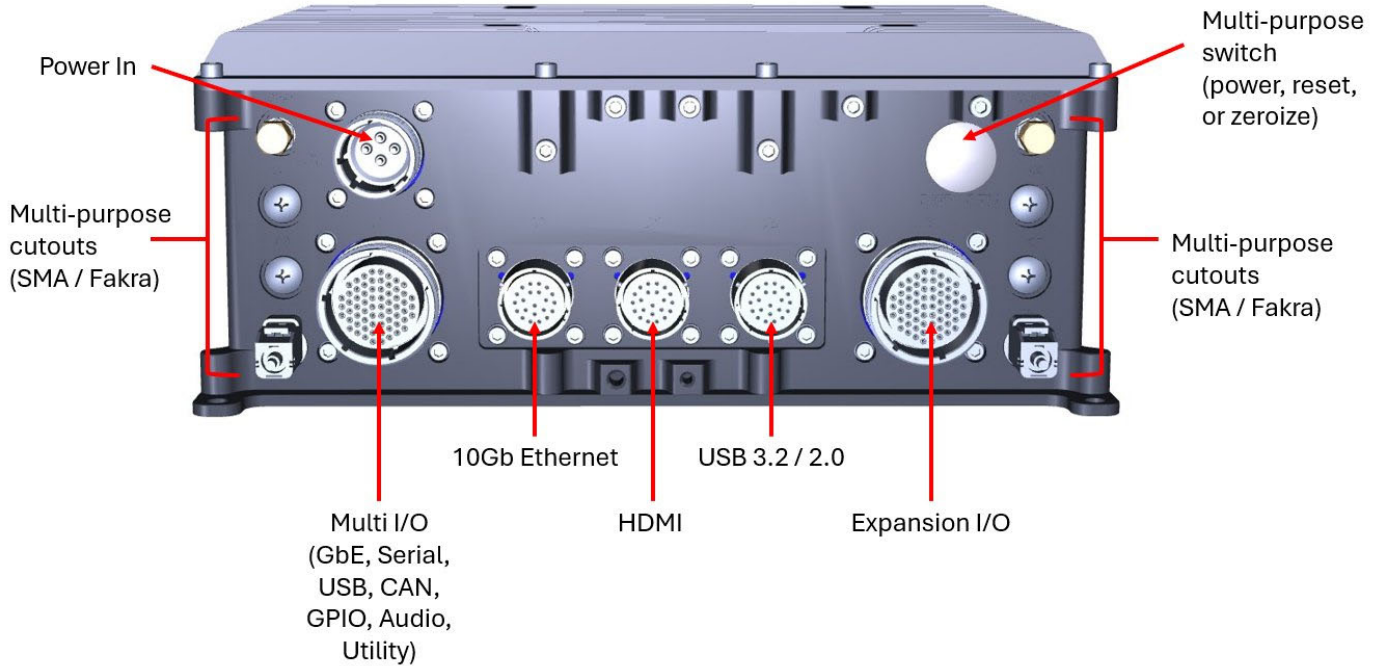

Figure 3: Mechanical outline, top view

8. I/O CONNECTORS

The following image shows the connector details on Geode Osbourne system.



Geode-OSB ships with caps for all connectors except for power input. The caps are attached to the front panel.

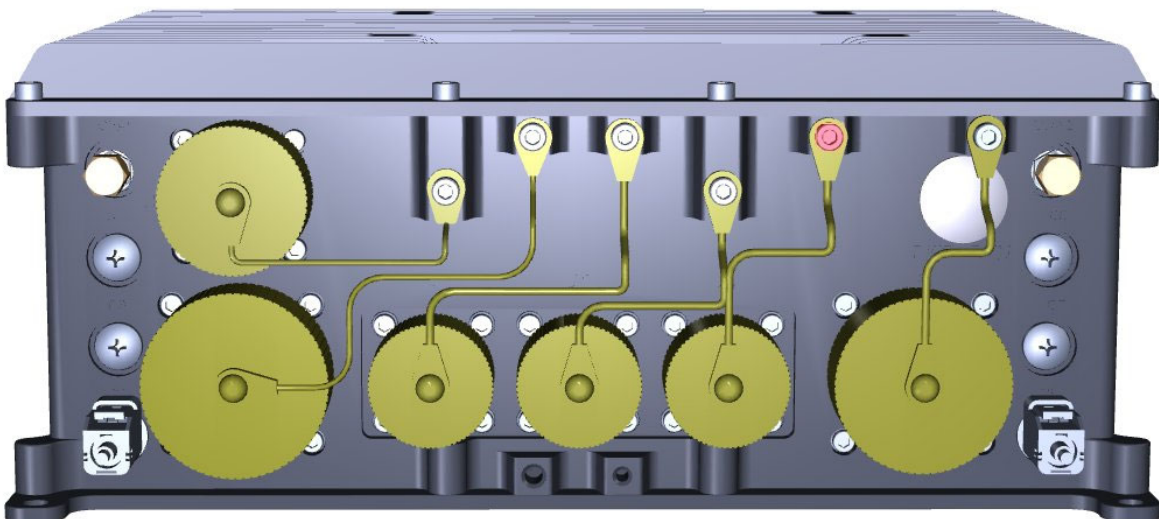

8.1 J1 - Power Input

Geode-OSB provides a D38999 series circular connector for power input. Connector pinout is as shown below.

Note: Power input is connected to J8 on rugged IO board when no internal power supply is included in Geode Osbourne. Power input is applied to J14 on Osbourne carrier board through internal power module when internal power supply module is used.

Interface	Osbourne Carrier Board Conn	Signal Description	IO Board Internal Conn	IO Board External Connector (38999)	External Cable Assy Connector
Power In	J14-01	Common	J8-01	J2-A	NA
Power In	J14-03	Common	J8-03	J2-B	NA
Power In	J14-02	Vin	J8-06	J2-C	NA
Power In	J14-04	Vin	J8-08	J2-D	NA

Geode system connector	Connector Part#	MIL D38999/20WC4PN	
	Description	Shell type	Straight Plug
		Material and finish	Olive Drab Cadmium Plated Nickel Base
		Shell Size	C
		Insert Arrangement	C4
		Contact type	Pin
		Keying position	Normal Keying
		Pins	4
Mating connector	Connector Part#	MIL D38999/26WC4SN	

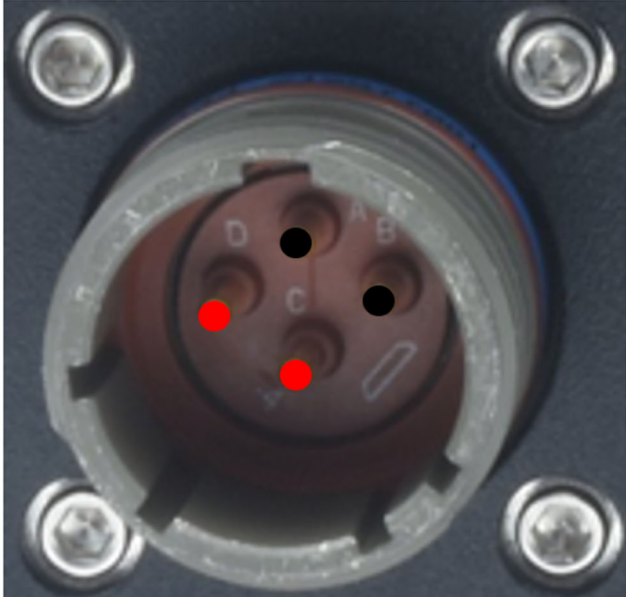
Illustration Viewed from exterior	
--------------------------------------	--

8.2 J2 – Multi-I/O Connector

The 1G Eth, 2x CAN, DIO, Audio, 4x Serial ports, 2x USB2.0 and Control Signals of the Geode System are terminated with a D38999 series circular connector. The connector pinouts are as shown below:

Interface	Osbourne Carrier Board Conn	Signal Description	IO Board Internal Conn	IO Board External Connector (38999)	External Cable Assy Connector
1G Ethernet Port 1	J4-108	GBEO_TR2_P	J9-108	J2-01	RJ45 jack-05
1G Ethernet Port 1	J4-114	GBEO_TR3_P	J9-114	J2-02	RJ45 jack-07
1G Ethernet Port 1	J4-116	GBEO_TR3_N	J9-116	J2-03	RJ45 jack-08
1G Ethernet Port 1	J4-98	GBEO_TR0_N	J9-98	J2-04	RJ45 jack-02
1G Ethernet Port 1	J4-110	GBEO_TR2_N	J9-110	J2-05	RJ45 jack-06
1G Ethernet Port 1	J4-96	GBEO_TR0_P	J9-96	J2-10	RJ45 jack-01
1G Ethernet Port 1	J4-102	GBEO_TR1_P	J9-102	J2-17	RJ45 jack-03
1G Ethernet Port 1	J4-104	GBEO_TR1_N	J9-104	J2-25	RJ45 jack-04
Audio Port	J4-03	AUDIO_HPOL_HDA	J9-03	J2-50	3.5mm Audio Jack-1 A
Audio Port		GND_AUD		J2-56	3.5mm Audio Jack-1 C
Audio Port	J4-01	AUDIO_HPOR_HDA	J9-01	J2-57	3.5mm Audio Jack-1 B
Audio Port		GND_AUD	J9-06	J2-60	3.5mm Audio Jack-2 C
Audio Port	J4-06	AUDIO_MIC_R	J9-06/04	J2-61	3.5mm Audio Jack-2 A
Audio Port		No Connect (NC)			3.5mm Audio Jack-2 B
CAN Port 0	J4-79	CAN0_H	J9-79	J2-06	DSUB 25-06
CAN Port 0	J4-77	CAN0_L	J9-77	J2-07	DSUB 25-19
CAN Port 0		GND_DIG		J2-08	DSUB 25-07
CAN Port 1	J4-75	CAN1_H	J9-75	J2-22	DSUB 25-20
CAN Port 1	J4-73	CAN1_L	J9-73	J2-23	DSUB 25-08
CAN Port 1		GND_DIG		J2-24	DSUB 25-18
DIO Port	J4-23	DIO_PA1	J9-23	J2-18	DSUB 25-22
DIO Port	J4-25	DIO_PA0	J9-25	J2-26	DSUB 25-09
DIO Port	J4-21	DIO_PA2	J9-21	J2-27	DSUB 25-10
DIO Port	J4-19	DIO_PA3	J9-19	J2-28	DSUB 25-23
DIO Port	J4-17	DIO_PA4	J9-17	J2-29	DSUB 25-11
DIO Port	J4-15	DIO_PA5	J9-15	J2-30	DSUB 25-24
DIO Port	J4-13	DIO_PA6	J9-13	J2-31	DSUB 25-12
DIO Port	J4-11	DIO_PA7	J9-11	J2-32	DSUB 25-25
DIO Port		GND_DIG		J2-33	DSUB 25-21
Expansion Port DSUB 25		GND_DIG		J2-59	DSUB 25-13
I2C Port		GND_DIG		J2-46	DSUB 25-04
I2C Port	J4-99	I2C_GP8_CLK_3P3	J9-99	J2-52	DSUB 25-03
I2C Port	J4-97	I2C_GP8_DAT_3P3	J9-97	J2-53	DSUB 25-16
I2C Port	J4-07	V_5P0_A	J9-07	J2-54	DSUB 25-05
Power Signals	J4-103	SYS_RST_IN_N	J9-103	J2-45	DSUB 25-01
Power Signals	J4-101	BUTTON_POWER_ON_N	J9-101	J2-47	DSUB 25-02
Power Signals	J4-113	MEM_ERS	J9-113	J2-48	DSUB 25-17
Power Signals	J4-105	FORCE_RECOVERY	J9-105	J2-49	DSUB 25-14

Power Signals		GND_DIG		J2-55	DSUB 25-15
Serial Port 1	J4-95	TX1/TX1_P/RX1_P	J9-95	J2-11	DB9_1-03
Serial Port 1	J4-93	RTS1/TX1_N/RX1_N	J9-93	J2-12	DB9_1-07
Serial Port 1	J4-91	RX1/RX1_P	J9-91	J2-13	DB9_1-02
Serial Port 1	J4-89	CTS1/RX1_N	J9-89	J2-14	DB9_1-08
Serial Port 1	J4-70	GND	J9-70	J2-15	DB9_1-05
Serial Port 1	NC	GND_CHASSIS	Access pad	J2-63	NC
Serial Port 2	J4-85	RTS2/TX2_N/RX2_N	J9-85	J2-09	DB9_2-07
Serial Port 2	J4-87	TX2/TX2_P/RX2_P	J9-87	J2-16	DB9_2-03
Serial Port 2	J4-83	RX2/RX2_P	J9-83	J2-19	DB9_2-02
Serial Port 2	J4-81	CTS2/RX2_N	J9-81	J2-20	DB9_2-08
Serial Port 2	J4-64	GND		J2-21	DB9_2-05
Serial Port 2	NC	GND_CHASSIS	Access pad	J2-63	NC
Serial Port 3	NC	GND_CHASSIS	Access pad	J2-34	NC
Serial Port 3	J4-55	UART5_TX_RS232	J9-55	J2-35	DB9_3-03
Serial Port 3	J4-51	UART5_RX_RS232	J9-51	J2-36	DB9_3-02
Serial Port 3	J4-49	UART5_CTS_RS232	J9-49	J2-37	DB9_3-08
Serial Port 3	J4-53	UART5_RTS_RS232	J9-53	J2-38	DB9_3-07
Serial Port 3	J4-58	GND_DIG		J2-39	DB9_3-05
Serial Port 4	NC	GND_CHASSIS	Access pad	J2-34	NC
Serial Port 4	J4-57	UART3_9_RX_RS232	J9-57	J2-40	DB9_4-02
Serial Port 4	J4-59	UART3_9_TX_RS232	J9-59	J2-41	DB9_4-03
Serial Port 4	J4-52	GND_DIG		J2-42	DB9_4-05
USB2.0 port1	J4-46	GND_DIG		J2-62	USB2.0 Type A-Female port1-04
USB2.0 port1	J4-61	V_USB2_VBUS	J9-61	J2-64	USB2.0 Type A-Female port1-01
USB2.0 port1	J4-65	USB2_HUB_D4_CH_P	J9-65	J2-65	USB2.0 Type A-Female port1-03
USB2.0 port1	J4-63	USB2_HUB_D4_CH_N	J9-63	J2-66	USB2.0 Type A-Female port1-02
USB2.0 port2	J4-31	USB2_D1_CH_P	J9-31	J2-43	USB2.0 Type A-Female port2-03
USB2.0 port2	J4-67	V_USB3_3	J9-67	J2-44	USB2.0 Type A-Female port2-01
USB2.0 port2	J4-29	USB2_D1_CH_N	J9-29	J2-51	USB2.0 Type A-Female port2-02
USB2.0 port2	J4-40	GND_DIG		J2-58	USB2.0 Type A-Female port2-04

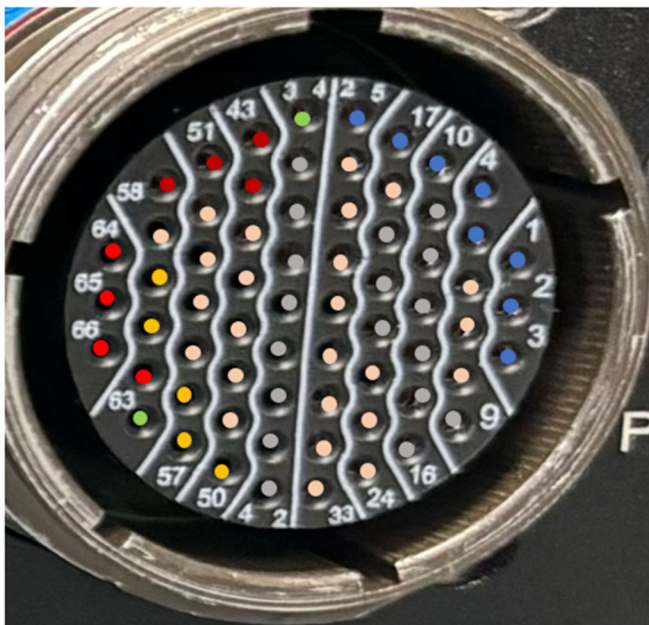
Geode system connector	Connector Part#	MIL D38999/20WF35SN	
	Description	Shell type	Straight Receptacle
		Material and finish	Olive Drab Cadmium Plated Nickel Base
		Shell Size	F
		Insert Arrangement	F35
		Contact type	Socket
		Keying position	Normal Keying
Mating connector	Connector Part#	MIL D38999/26WF35PN	
Illustration Viewed from exterior	 <ul style="list-style-type: none"> ● 1G Ethernet ● USB2.0 Port1 ● USB2.0 Port2 ● Serial 1-4 ● CAN, PWR Signals & DIOs ● Audio 		

8.3 J3 – 10Gb Ethernet

Geode-OSB provides two Gigabit Ethernet which are terminated with SJT00RT12 series circular connector. Connector pinout is as shown below:

Interface	Osbourne Carrier Board Conn	Signal Description	IO Board Internal Conn	IO Board External Connector (38999)	External Cable Assy Connector
10G Ethernet Port 1	J4-122	MGBEO_A_N	J9-122	J3-03	RJ45 jack-02
	J4-120	MGBEO_A_P	J9-120	J3-04	RJ45 jack-01
	J4-128	MGBEO_B_N	J9-128	J3-18	RJ45 jack-04
	J4-126	MGBEO_B_P	J9-126	J3-22	RJ45 jack-03
	J4-132	MGBEO_C_N	J9-132	J3-01	RJ45 jack-06
	J4-134	MGBEO_C_P	J9-134	J3-14	RJ45 jack-05
	J4-140	MGBEO_D_N	J9-140	J3-11	RJ45 jack-08
	J4-138	MGBEO_D_P	J9-138	J3-12	RJ45 jack-07
NA	NC	NA	NC	J3-02	NC
NA	NC	NA	NC	J3-05	NC
NA	NC	NA	NC	J3-06	NC
NA	NC	NA	NC	J3-07	NC
NA	NC	NA	NC	J3-08	NC
NA	NC	NA	NC	J3-09	NC
NA	NC	NA	NC	J3-10	NC
NA	NC	NA	NC	J3-13	NC
NA	NC	NA	NC	J3-15	NC
NA	NC	NA	NC	J3-16	NC
NA	NC	NA	NC	J3-17	NC
NA	NC	NA	NC	J3-19	NC
NA	NC	NA	NC	J3-20	NC
NA	NC	NA	NC	J3-21	NC

Geode system connector	Connector Part#	MIL SJT00RT12-35S014	
	Description	Shell type	Straight Receptacle
		Material and finish	Olive Drab Cadmium Plated Nickel Base
		Shell Size	12
		Insert Arrangement	12-35
		Contact type	Female Socket
		Keying position	Normal Keying
		Pins	22
Mating connector	Connector Part#	MIL SJTG06RT12-35DP014	

Illustration Viewed from exterior

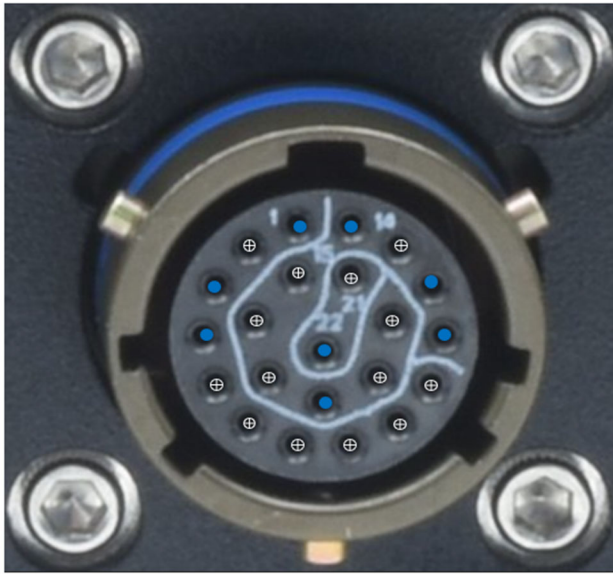

● 10G Ethernet

8.4 J4 – HDMI

Geode-OSB provides HDMI interface signals which are terminated with SJT00RT12 series circular connector. Connector pinout is as shown below:

Interface	Osbourne Carrier Board Conn	Signal Description	IO Board Internal Conn	IO Board External Connector (38999)	External Cable Assy Connector
HDMI Port	J4-36	HDMI_DP2_TX0_CON_P	J9-36	J4-01	HDMI-01
	J4-38	HDMI_DP2_TX0_CON_N	J9-38	J4-02	HDMI-03
	J4-56	HDMI_DP2_TX1_CON_P	J9-56	J4-03	HDMI-04
	J4-54	HDMI_DP2_TX1_CON_N	J9-54	J4-04	HDMI-06
	J4-50	HDMI_DP2_TX2_CON_P	J9-50	J4-05	HDMI-07
	J4-48	HDMI_DP2_TX2_CON_N	J9-48	J4-06	HDMI-09
	J4-47	HDMI_HPD_CON	J9-47	J4-07	HDMI-19
Unused	NC	NC	NC	J5-08	NC
HDMI Port	J4-42	HDMI_DP2_TX3_CON_P	J9-42	J4-09	HDMI-10
	J4-44	HDMI_DP2_TX3_CON_N	J9-44	J4-10	HDMI-12
	NC	GND_CHASSIS	NC	J4-11	NC
	J4-41	HDMI_SCL_CON	J9-41	J4-12	HDMI-15
	J4-43	HDMI_SDA_CON	J9-43	J4-13	HDMI-16
		GND_DIG		J4-14	HDMI-17
		GND_DIG		J4-15	HDMI-02
		GND_DIG		J4-16	HDMI-05
		GND_DIG		J4-17	HDMI-08
	NC	GND_CHASSIS	NC	J4-18	NC
		GND_DIG		J4-19	HDMI-11
	J4-45	HDMI_CEC_CON	J9-45	J4-20	HDMI-13
	J4-39	V_5P0_HDMI	J9-39	J4-21	HDMI-18
		GND_DIG		J4-22	NC
	NC	NC	NC	NC	HDMI-14

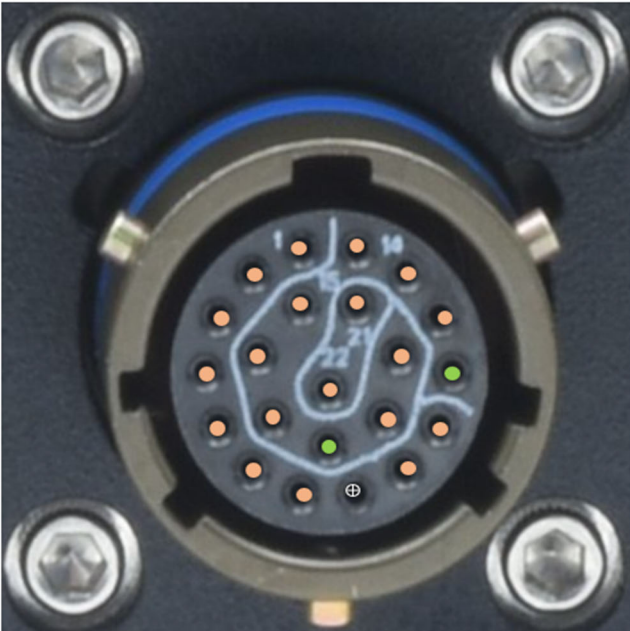
Geode System connector	Connector Part#	MIL SJT00RT12-35S014	
	Description	Shell type	Straight Receptacle
		Material and finish	Olive Drab Cadmium Plated Nickel Base
		Shell Size	12
		Insert Arrangement	12-35
		Contact type	Female Socket
		Keying position	Normal Keying
		Pins	22
Mating connector	Connector Part#	MIL SJTG06RT12-35DP014	
Illustration Viewed from exterior			

8.5 J5 – USB3.2

Geode-OSB provides 2xUSB3.2 ports with USB 2.0 fallback on an SJT00RT12 series circular connector. Connector pinout is as shown below:

Interface	Osbourne Carrier Board Conn	Signal Description	IO Board Internal Conn	IO Board External Connector (38999)	External Cable Assy Connector
USB3.0 Port 0	J4-27	VBUS	J9-27	J5-01	USB3.0 Type A_1 - 01
	J4-69	D-	J9-69	J5-07	USB3.0 Type A_1 - 02
	J4-71	D+	J9-71	J5-08	USB3.0 Type A_1 - 03
		GND		J5-02	USB3.0 Type A_1 - 04
	J4-14	StdA_SSRX-	J9-14	J5-05	USB3.0 Type A_1 - 05
	J4-12	StdA_SSRX+	J9-12	J5-06	USB3.0 Type A_1 - 06
		GND		J5-16	USB3.0 Type A_1 - 07
	J4-20	StdA_SSTX-	J9-20	J5-03	USB3.0 Type A_1 - 08
	J4-18	StdA_SSTX+	J9-18	J5-04	USB3.0 Type A_1 - 09
		NC	NC	J5-15	NC
USB3.0 Port 1	J4-33	VBUS	J9-33	J5-14	USB3.0 Type A_2 - 01
	J4-35	D-	J9-35	J5-22	USB3.0 Type A_2 - 02
	J4-37	D+	J9-37	J5-18	USB3.0 Type A_2 - 03
		GND		J5-19	USB3.0 Type A_2 - 04
	J4-26	StdA_SSRX-	J9-26	J5-11	USB3.0 Type A_2 - 05
	J4-24	StdA_SSRX+	J9-24	J5-12	USB3.0 Type A_2 - 06
		GND		J5-19	USB3.0 Type A_2 - 07
	J4-32	StdA_SSTX-	J9-32	J5-09	USB3.0 Type A_2 - 08
	J4-30	StdA_SSTX+	J9-30	J5-10	USB3.0 Type A_2 - 09
		NC	NC	J5-21	NC
Unused	NC	NC	NC	J5-17	NC
	NC	NC	NC	J5-20	NC

Geode system connector	Connector Part#	MIL SJT00RT12-35S014
	Description	Shell type Straight Receptacle Material and Olive Drab Cadmium finish Plated Nickel Base Shell Size 12 Insert Arrangement 12-35 Contact type Female Socket Keying position Normal Keying Pins 22
Mating connector	Connector Part#	MIL SJTG06RT12-35DP014

Illustration
Viewed from exterior

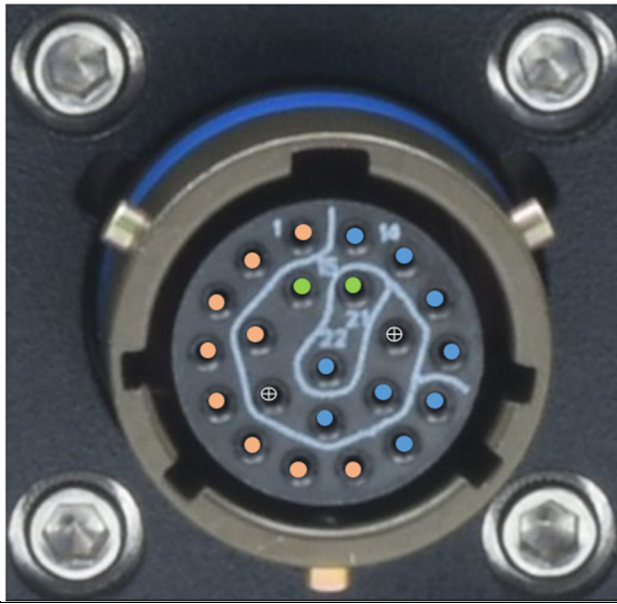

- USB 3.0 Port 1
- USB 3.0 Port 2
- GND_CHASSIS

9. JUMPER CONFIGURATION

9.1 Jumper Blocks

The Jumper blocks on the Osbourne baseboard can be configured to enable/disable or alter the default signal routing settings on the circuit, using Jumper shunts. The following table describes the Jumper Blocks on the baseboard.

Ref	Function
JP1	Serial Termination Enable/Disable
JP2	DIO voltage selection/DIO push pull selection
JP3	PCIe/Minicard selection, Configuration, WOL, Auto Power Selection

Refer Osbourne Base Board User Manual for more information.

9.2 Serial Port Termination (JP1)

JP1 jumpers are provided enable and disable the termination of serial ports1-2.

Position	Function	IN	OUT
TX1	121E Termination Enabled for SER1 TX RS-485/RS-422 Mode	Enabled	Disabled*
RX1	121E Termination Enabled for SER1 RX RS-485/RS-422 Mode	Enabled	Disabled*
TX2	121E Termination Enabled for SER2 TX RS-485/RS-422 Mode	Enabled	Disabled*
RX2	121E Termination Enabled for SER2 RX RS-485/RS-422 Mode	Enabled	Disabled*

*Default setting

The following image shows the jumper configuration with all serial port terminations disabled.

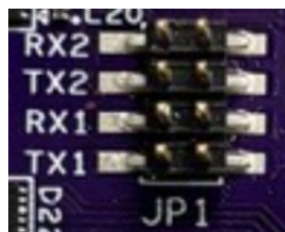

9.3 DIO Jumper Selection (JP2)

JP2 Jumpers are provided to select the voltage level and Pullup/pull down configuration of the DIO. By default, the DIOs are 3.3 Volare pulled down. The configuration is as shown below:

Position	Function	IN	OUT
5V	DIO Voltage Level	5V	
3V3	DIO Voltage Level	3.3V*	
PU	DIO Pull up Enable	Enabled	Disabled
PD	DIO Pull down Enable	Enabled*	Disabled

*Default setting

Note: Make sure 5V and 3V3 Jumper are not IN at the same time!

The following image shows jumper configurations for 3.3V voltage level and PD enabled.

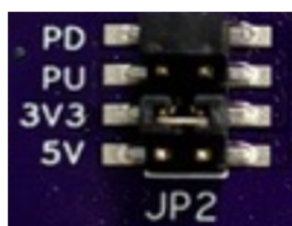

9.4 Configuration Jumper Selection (JP3)

JP3 Jumpers Configuration are provided for various selection and configuration.

Position	Function	IN	OUT
PCIE	x16 PCIe / Minicard1 Selection	Minicard1*	x16 PCIE
CFG	USB2/PCIE_CONFIG_SEL	USB Configuration#1*	mPCIe Configuration#2
WOL	Wake on LAN	Enabled	Disabled*
AUTO	Auto Power ON	Disabled	Enabled*

*Default setting

Notes:

- PCIE Position provides the option to select between the Minicard1 card or x16 Pcie card
- Wake on LAN function is currently not supported by the design.
- mPCIe Configuration#2 functions is currently not supported by the current BSP.
- Bottom port of J14 USB connector work as PCIe, during mPCIe configuration#2.

The following image shows jumper configuration with Minicard 1, USB Configuration#1 selected and Wake on LAN and Auto power on features disabled.

